

# LIGHT SAND

SAN Connectivity

## Solutions and Products Overview 2023

BRIDGING YOUR BUSINESSES  
INTERCONNECTING your SAN's



BRIDGING YOUR BUSINESSES  
INTERCONNECTING your SAN's

# LIGHT SAND

*Founded in 1999, LightSand provides cost effective edge SAN/WAN products that power efficiently the interconnection of multiple data management applications regardless of protocols, physical proximity or vendor disparity.*

The company addresses the emerging problem of connecting remote Storage Area Network (SAN/LAN) locations over any distance, with applications in banking and finance, telecommunications, healthcare, media, retail, utilities, industry, services, defense and aerospace. LightSand solutions simplify SAN interconnections over any MAN/WAN. This technology enables any data protection applications to be implemented in a remote disaster recovery environment with unprecedented levels of performance.

## ► LIGHTSAND CONNECTIVITY SOLUTIONS

LightSand has developed a number of SAN interconnectivity products which can help you connect multiple sites, protect critical data, optimize network infrastructure and reduce TCO.

LightSand provides a family of gateways that addresses the growing problem of connecting remote SAN locations over distance. There are many ways to move Fibre Channel or FICON data over metropolitan and wide area Networks : FC/FICON and Ethernet Layer 2 over SONET/SDH, IP, Dark Fiber

and Dedicated Fiber. LightSand offers products that address all of these protocols. Our products can route your FC or FICON data together with Ethernet Layer 2 data over MAN/WAN Networks.

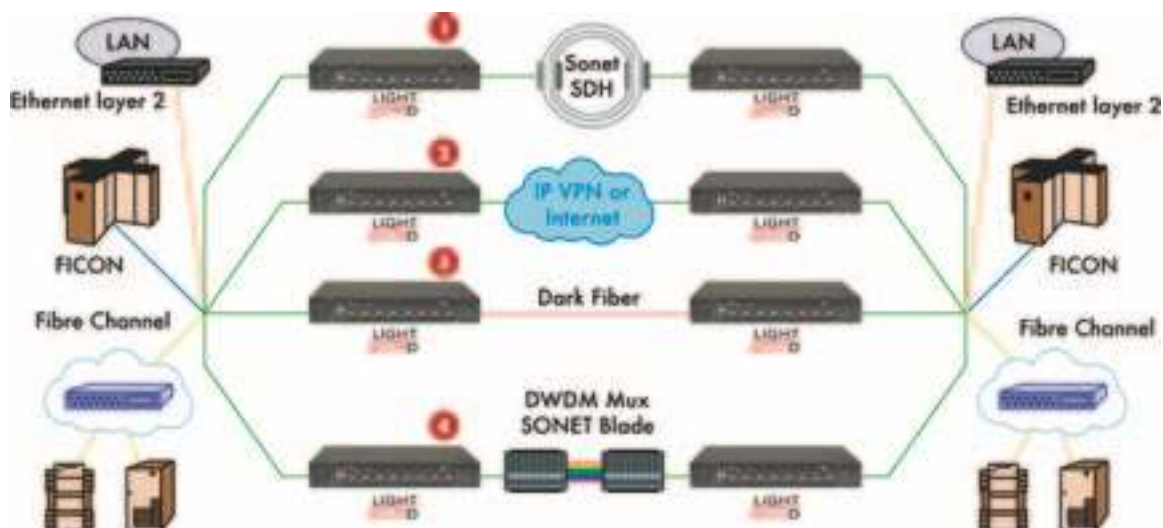

- 1 > Fibre Channel or FICON and Ethernet Layer 2 over SONET/SDH
- 2 > Fibre Channel or FICON and Ethernet Layer 2 over IP
- 3 > Fibre Channel or FICON and Ethernet Layer 2 over Dark Fiber
- 4 > Fibre Channel or FICON and Ethernet Layer 2 over DWDM

# ▶ LIGHTSAND REVOLUTIONARY PLATFORM : i-SWAN™

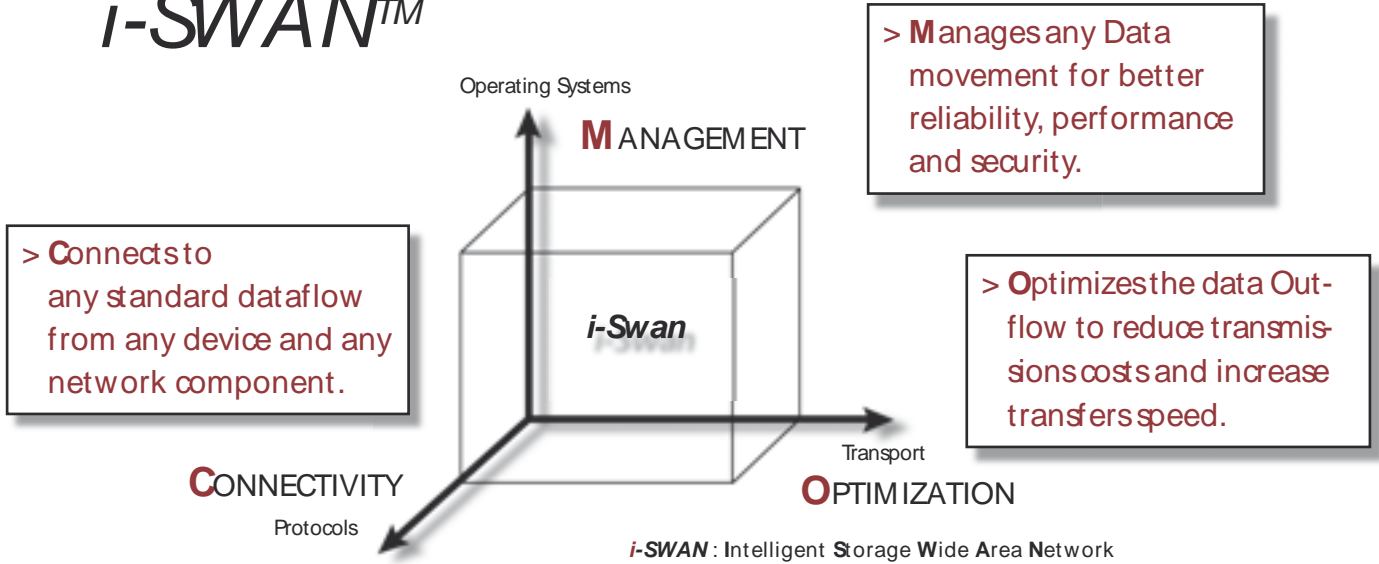

LightSand's revolutionary **i-SWAN™** platform combines unique market capabilities to alleviate sites inter-connections issues. With its multilayered architectures, it brings unique combination of Customer benefits running over multiple hardware platform targeting SMB or Enterprise markets. With the **Connectivity** capabilities, **i-SWAN™** enables customers

to connect to any standard dataflow from any device and any network component. The **i-SWAN™ Optimization** of the Data Outflow helps customers to reduce transmissions costs and increase transfers. Finally with the **Management** capabilities, all data movements are controlled and optimized for better reliability, performance and security.



## ▶ MULTI-LAYERS ARCHITECTURE

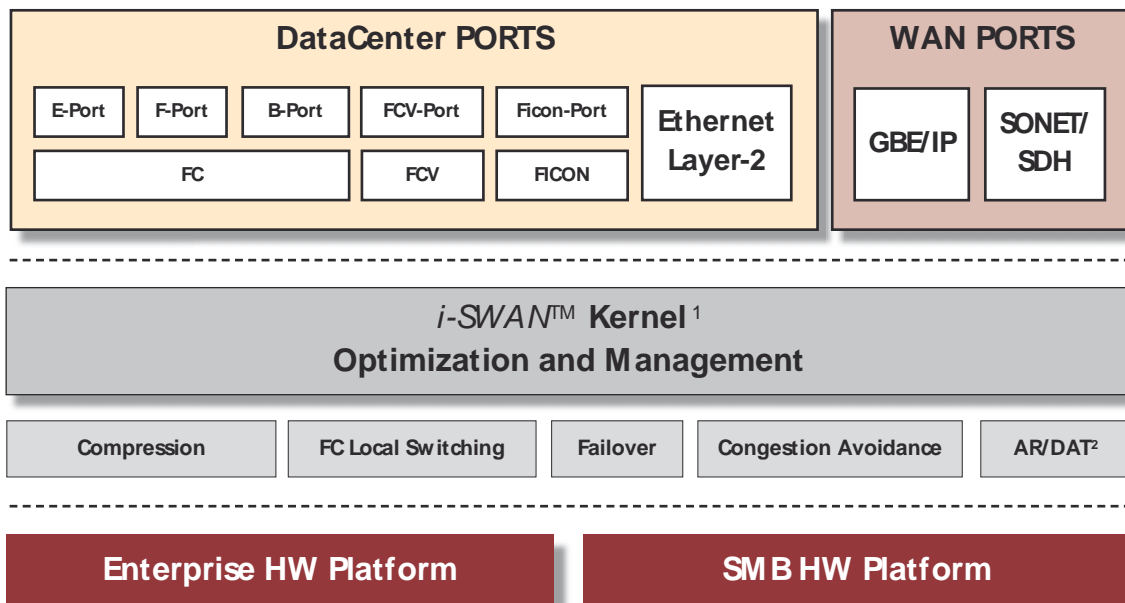

<sup>1</sup> i-SWAN Kernel can run on any compatible HW platform - <sup>2</sup> Autonomous Region, Domain Address Translation

## ▶ *i-SWAN*<sup>TM</sup> OPEN CONNECTIVITY

### > **FICON/FCV ports :**

Extends Mainframe connectivity and devices with/without requiring Director switches.

### > **Ethernet Layer 2 port :**

Low layer ethernet high performance extension required for « non » IP based traffic extension : Cluster, iSCSI, netbui, novell, VMS, etc.

### > **E-Port with SAN Isolation :**

Virtualizes Remote hardware without merging Fabrics.

Keeps native mode for local Fabrics.

Prevents local fabrics from WAN intrusions and disruptions.

### > **B-Port Connectivity :**

Transparency in the extension.

No need to « downgrade » vendor fabrics to compatibility mode.

### > **F-Port Connectivity :**

Allows direct host or device attachment without using SAN switches.

## ▶ *i-SWAN*<sup>TM</sup> OPEN PLATFORM

### ***i-SWAN*<sup>TM</sup> PLATFORM CAN INTEROPERATE WITH :**

#### > **Any SAN Vendor :**

EMC, HP, HDS, IBM, STK, Dell, Brocade, McData, Cisco...

#### > **Any Operating System :**

Unix, Mainframe, Fabric OS and other...

#### > **Any Application :**

Data Movement, Data replication, Remote Backup, Data Encryption, Filesystems,

#### > **Any Network :**

IP, SONET, DWDM, SDH, Dark Fiber...



## ▶ **i-SWAN™ ADVANCED MANAGEMENT**

### > **Local FC switching :**

Manage FC traffic from Port to Port in switching architecture.  
Standalone solution for local SAN based applications.

### > **B-Port Trunking**

Allows multiplexing of different and independent SAN traffics over the WAN.

### > **AR/DAT : Autonomous Regions and Domain Address Translation**

Virtualization of remote hardware within local third party fabrics.  
Local Fabric isolation and protection against intrusions or WAN disruptions.

### > **Traffic Multiplexing :**

Mixes Storage Traffics (FC or FICON) with Ethernet Traffics.

### > **SAN Management Interface :**

Advanced Graphic User Interface to manage global interconnected Fabrics.

## ▶ **i-SWAN™ OPTIMIZATION AND HIGH PERFORMANCE**

### > **WAN protocol independence:**

*i-SWAN™* platform runs over GBE, SONET/SDH, IP Networks.

### > **High reliable transport protocol**

Guaranteed data and order delivery.  
Adjusted to latency sensitive applications.

### > **High performance :**

Up to 4 Gb/s native output. Up to 6000 km on wire-speed without performance degradation.

### > **Compression :**

Up to 1:21 max compression, 1:3 to 1:5 observed in Production.

### > **Congestion Avoidance or Manual Rate Adaptation :**

Maintains Maximum performance on shared networks or low bandwidth connections.  
Allows to fix maximal bandwidth utilization useful when sharing data traffic with other applications (e.g. VoIP) on guaranteed SLA.

### > **WAN failover :**

Automatic and transparent WAN failover management.

# ▶ SAN ISOLATION AND INTERCONNECTION OF HETEROGENEOUS FC FABRICS. AR/DAT



- > AR/DAT (Autonomous regions/Domain Address Translation) gateways provide SAN isolation and interconnection of heterogeneous FC fabrics and LANs over Sonet/SDH or routed IP Networks.
- > Allows individual FC fabrics to be connected without actually merging, and still share devices. As a result, any disruptions are fully isolated in the local FC fabric.
- > Enables heterogeneous SAN integration by interconnecting multi-vendor remote fabrics, which are not usually interoperable.
- > Avoids configuration conflicts by reducing Zone strategy, correlation parameters and allowing overlapped FC addresses in attached ARs,
- > Provides new level of security for SAN fabrics – Shares devices in a unique export/import firewall-like mechanism.
- > AR/DAT gateways support interoperability within a heterogeneous SAN providing basic services for native modes of major FC switch vendors and all mandatory FC services (PSS, FSPF, Zoning, Name, Configuration servers, etc.) as well as local switching and direct device attachment.

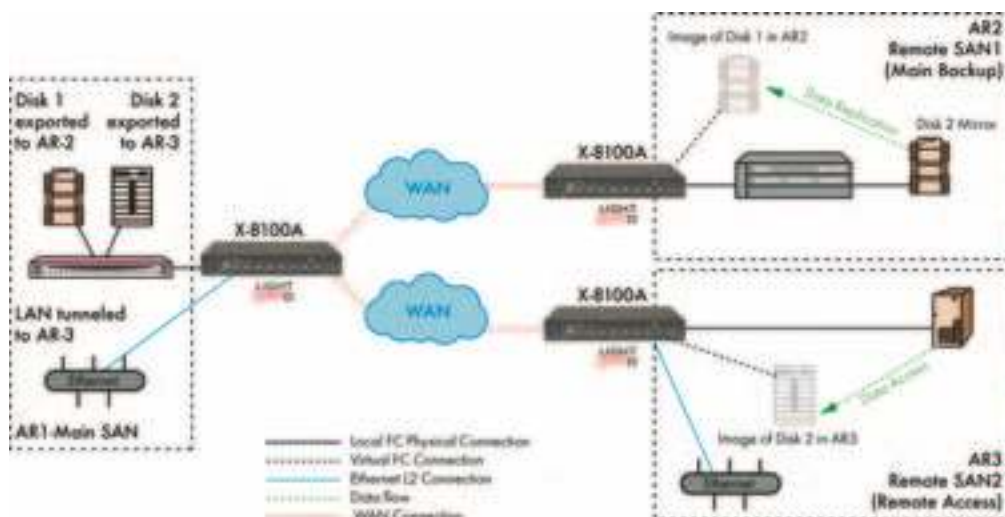

# ► FICON EXTENSION OVER DISTANCE F-TYPE



- > The 'F' type gateways are flexible and powerful FICON and LANs over SONET/SDH or routed IP gateways.
- > Overcomes standard FICON distance limitations - FICON devices separated by thousands of kilometers can now communicate, no expensive FICON directors are necessary to provide FICON extension across the WAN. The 'F' type gateway is designed to interface directly with FICON mainframe and storage devices.
- > Implements trunking mechanism allowing cost effective deployments of up to seven parallel

- FICON channels and/or LANs clustered over a single WAN connection.
- > Supports redundant connections for high availability and load balancing: When multiple WAN interfaces are installed, each FICON input can be directed through a separate WAN interface, providing optimal data traffic distribution. If one WAN connection fails, traffic is automatically redistributed through the remaining healthy connections, providing complete recovery on the gateway rather than on the FC fabric level.

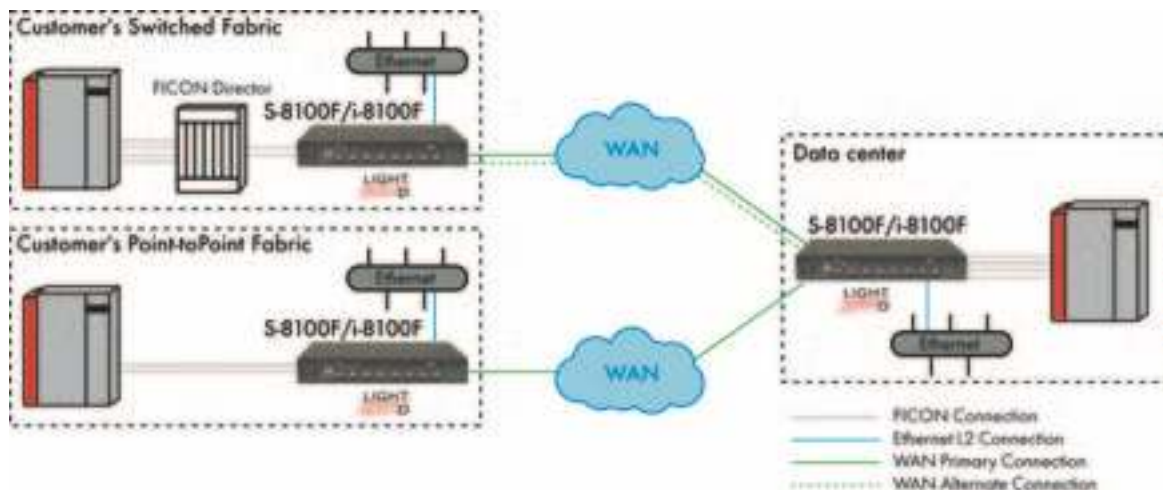



# ▶ TRANSPARENT AND PROTECTED INTERFACE B-TYPE



- > The 'B' type gateways are flexible and powerful FC and LANs over SONET/SDH or routed IP gateways.
- > Implements trunking mechanism allowing cost effective deployments of up to seven parallel FC fabrics and/or LANs over a single WAN connection.
- > Presents a "B" port to the local FC switch. This provides an industry standard interface that lets all standard and proprietary FC services pass from one remote site to another.
- > Supports redundant connections for high availability and load balancing: When multiple WAN interfaces are installed, each FC input can be directed through a separate WAN interface, providing optimal data traffic distribution. If one WAN connection fails, traffic is automatically redistributed through the remaining healthy connections, providing complete recovery on the gateway rather than on the FC fabric level.

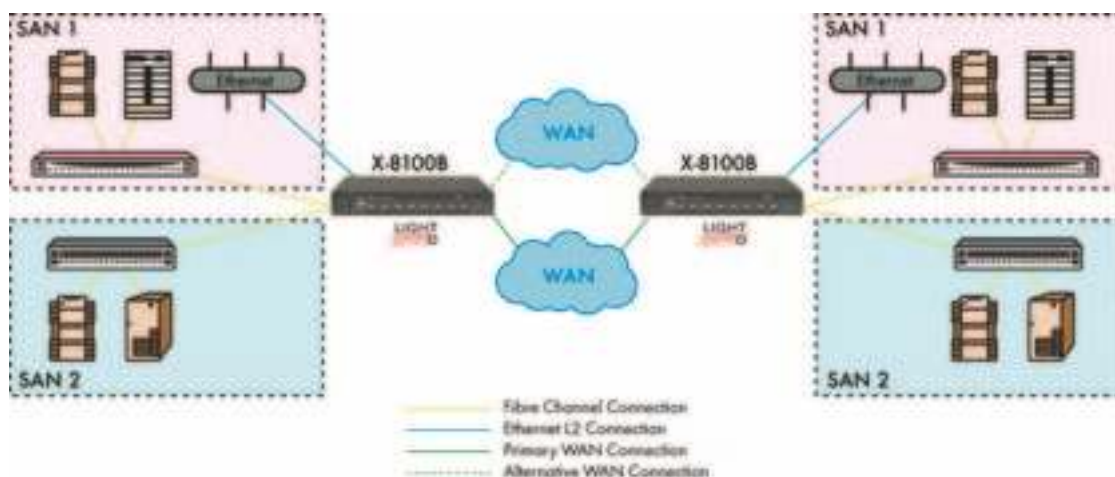

## ▶ LIGHTSAND SAN MANAGEMENT INTERFACE FOR FC FABRIC VISUALIZATION AND MONITORING

SANman is LightSand's advanced Graphic User Interface. In addition to the monitoring and configuration of LightSand SAN connectivity devices, SANman provides management features of the entire SAN fabric, including main fiber channel vendor devices.

Based on intuitive Drag-and-Drop functionalities, advanced visual displays and unique analysis tools, SANman is a powerful management utility which helps reduce the time and complexity of interconnecting, monitoring and managing remote SANs. SANman is an integrate part of all LightSand SAN interconnectivity solutions.

### MAIN FEATURES AND CAPABILITIES :

- > Easy access to LightSand devices for configuration and monitoring
- > Configuration and monitoring features of the main FC vendor switches (Brocade®, McDATA®, CISCO®)\*
- > Visual display and monitoring of the whole FC fabric topology and its components
- > Performance monitoring window
- > Name and Login servers viewer
- > Easy and intuitive Drag-And-Drop Zoning configuration facility
- > Automatic switch detection in the network according to user defined ranges
- > AR/DAT configuration facility
- > Simple frame analyzer
- > Long-run performance and event viewer application
- > Microsoft Windows based GUI application

## ▶ SANMAN IS INCLUDED WITH ALL LIGHTSAND SAN INTERCONNECTIVITY SOLUTIONS



**Topology View :**  
a graphic topological display of the selected fabric and the relationship between its elements ( Switches and Devices).

The topology is built automatically and changes in the Fabric are automatically detected by SANman. The display area is updated accordingly. The user may customize the display area by repositioning the elements or by assigning them various identification labels, as well as display Traffic and Zoning information.



**Switch View :**  
Provides a user-friendly graphic interface.

The switch View allows to fully configure, analyze and monitor LightSand gateways, as well as the configuration and monitoring of major fiber channel vendors FC switches.

List of all views available :

TOPOLOGY, SWITCH, STATISTICS, ZONING, LOGIN SERVER, NAME SERVER, ACTIVE, DEVICES, AUTODISCOVERY, TRAPS, FRAMES, STATISTICS



## ▶ EXTENSIVE MONITORING CAPABILITIES

Comprehensive and configurable reports for customers to indicate availability and performance



**Traffic Monitoring :**

- > Extensive Traffic Monitoring capabilities for reporting and troubleshooting purposes
- > Accumulated traffic monitor records for practically unlimited period of time (with the option to output to MS Excel file)
- > Wide variety of data provided including momentarily peaks for Link availability (3 layers), Traffic rates and link parameters (RTT, speed, etc.), Error counters and calculated variables (frame loss, bit error, etc.).

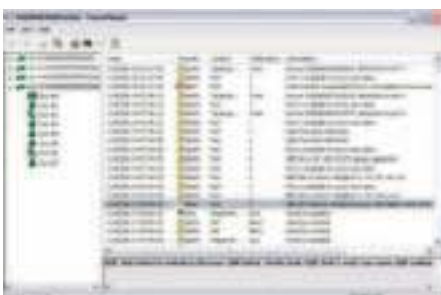

**Event Monitoring :**

- > Log files provide comprehensive information for monitoring and troubleshooting of the system
- > Records of the Event log provides full description of the event including troubleshooting recommendation in case of failure
- > The application can help find, sort, filter and print the events or the log file can be retrieved from the gateway as Text file.

## ► FIBRE CHANNEL OR FICON AND ETHERNET LAYER 2 OVER SONET

LightSand S-Series gateways provide the most efficient means of moving data at OC-3 and OC-12 rates. The ability to carry multiple protocols through a standard SONET or SDH circuit over distances of up to tens of thousands kilometers without performance degradation, and with data delivery guaranteed, provides for a truly global data infrastructure.

> The following LightSand products support Fibre Channel and Ethernet Layer 2 over SONET :

S-8100A / S-8100B / S-8100E

> The following LightSand product supports FICON and Ethernet Layer 2 over SONET/SDH :

S-8100F



## ► S-8100A

The S-8100A interconnects remote SANs and LANs over Sonet/SDH Networks.



- > S-8100A has eight ports : Layer 2 Ethernet, FC, SONET/SDH predefined per customer request and deployment objectives.
- > Embedded AR/DAT engine interconnects remote SANs without actually merging them - creating non-disruptive SANs which can share devices in a secure way.
- > Supports interoperability in all standard modes of major FC switch vendors (Brocade®, McDATA®, Cisco®, etc.)\*, as well as proprietary/native modes.
- > Supports local switching, direct device attachment and all mandatory and extended FC services (including zoning).
- > Engineered for Long Distance - transferring FC over POS using OC-3/STM-1 or OC-12c/STM-4 for distances of thousands of kilometers without performance degradation, and with data delivery guaranteed.
- > Uses Hardware Compression for more efficient utilization of low bandwidth or provisioned bandwidth connections - transferring more data while keeping the low price of the extension circuit.

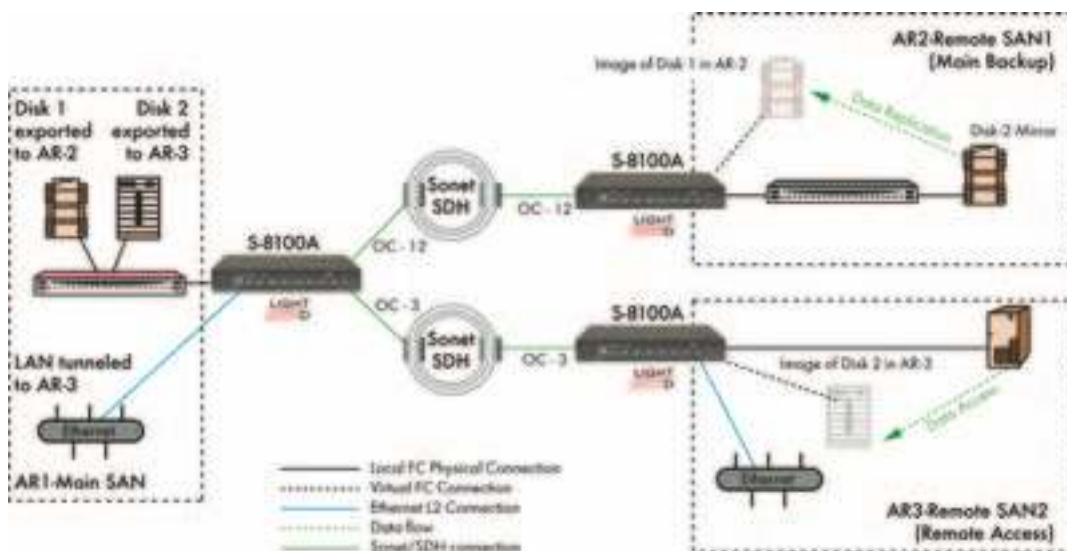



## ► S-8100B

The S-8100B is a flexible and powerful FC and LANs over SONET/SDH gateway.



- > S-8100B has eight ports : Layer 2 Ethernet, FC and SONET/SDH predefined per customer request and deployment objectives.
- > Implements trunking mechanism allowing cost effective deployments of up to seven parallel LAN or/and FC fabrics over a single Sonet/SDH WAN connection.
- > Presents a "B" port to the local FC switch. This provides an industry standard interface that lets all standard and proprietary FC services pass from one remote site to another.
- > Supports redundant connections for high availability and load balancing.
- > Engineered for Long Distance - transferring FC over POS using OC-3/STM-1 or OC-12c/STM-4 for distances of thousands of kilometers without performance degradation, and with data delivery guaranteed.
- > Uses Hardware Compression for more efficient utilization of low bandwidth or provisioned bandwidth connections - transferring more data while keeping the low price of the extension circuit.



## ► S-8100E

The S-8100E is a multi-functional interconnection gateway of FC fabrics and LANs over Sonet/SDH Networks.



- > S-8100E has eight ports : Layer 2 Ethernet/GbE, FC, SONET/SDH predefined per customer request and deployment objectives.
- > Implements E-Port connectivity and supporting all mandatory and extended FC services (PSS, FSPF, RSCN; Zone, Name, Configuration servers).
- > Supports interoperability in all standard modes of major FC switch vendors (Brocade®, McDATA®, Cisco®, etc.)\*, as well as proprietary/native modes.
- > Supports local switching and direct device attachment (F-Port).
- > Layer 2 device (GBE) may be attached and tunneled over FC fabric
- > Engineered for Long Distance - transferring FC over POS using OC-3/STM-1 or OC-12c/STM-4 for distances of thousands of kilometers without performance degradation, and with data delivery guaranteed.
- > Uses Hardware Compression for more efficient utilization of low bandwidth or provisioned bandwidth connections - transferring more data while keeping the low price of the extension circuit.

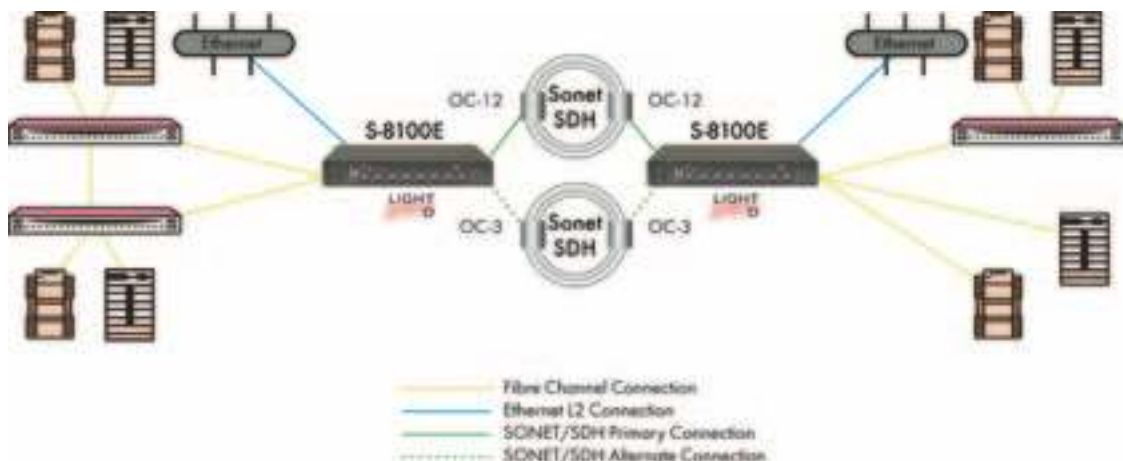

# ► S-8100F

The S-8100F is a flexible and powerful FICON and LANs over SONET/SDH gateway.



- > S-8100F has eight ports : Layer 2 Ethernet, FICON and SONET/SDH predefined per customer request and deployment objectives.
- > Can extend FICON devices without FICON director switches.
- > Implements trunking mechanism allowing cost effective deployments of up to seven parallel FICON channels and/or LANs over a single Sonet/SDH WAN connection.
- > Supports redundant connection for high availability and load balancing.
- > Engineered for Long Distance - transferring FICON over POS using OC-3/STM-1 or OC-12c/STM-4 for distances of thousands of kilometers without performance degradation, and with data delivery guaranteed.
- > Uses Hardware Compression for more efficient utilization of low bandwidth or provisioned bandwidth connections - transferring more data while keeping the low price of the extension circuit.

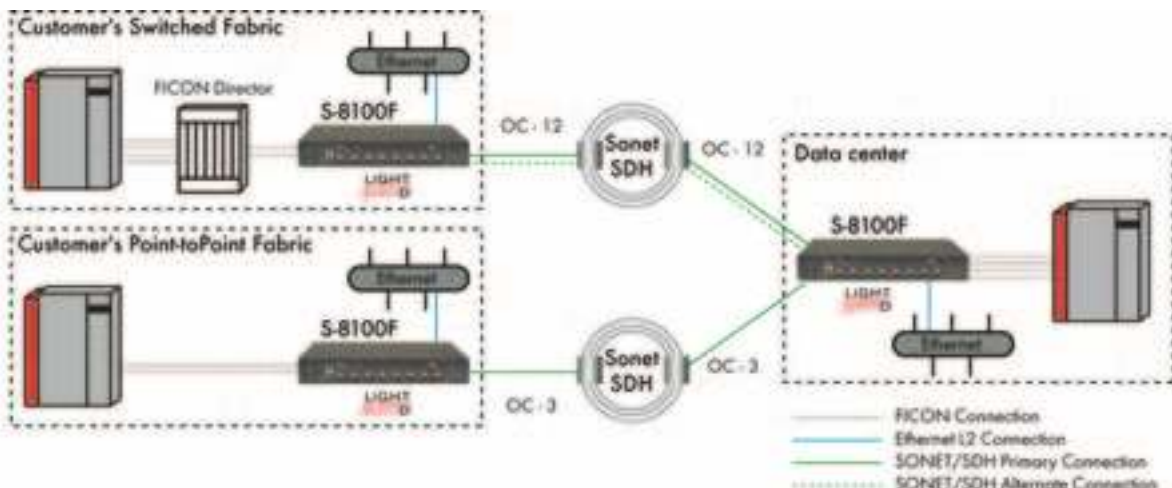

## ► FIBRE CHANNEL OR FICON AND ETHERNET LAYER 2 OVER IP

LightSand i-Series gateways provide flexible, reliable data movement of Fibre Channel, Layer 2 Ethernet and/or FICON data over new or existing IP Networks, without performance degradation, and with data and order delivery guaranteed.

The data rate can be optimized for anything from simple DSL connections up to the highest multi-gigabit Networks. i-Series gateways include traffic shaping mechanisms such as Manual Rate Limitation and Congestion Avoidance to allow maintaining maximal possible performance in shared or low bandwidth IP WAN environments.

> The following LightSand products support Fibre Channel and Ethernet Layer 2 over IP :

i-8100A / i-8100B / i-8100E

> The following LightSand product supports FICON and Ethernet Layer 2 over IP :

i-7100F



# ► i-8100A

The i-8100A interconnects remote SANs and LANs over routed IP Networks.



- > i-8100A has eight ports: Layer 2 Ethernet/GbE, FC, IP/GbE predefined per customer request and deployment objectives.
- > Embedded AR/DAT engine interconnects remote SANs without actually merging them - creating non-disruptive SANs which can share devices in a secure way.
- > Supports interoperability in all standard modes of major FC switch vendors (Brocade®, McDATA®, Cisco®, etc.)\*, as well as proprietary/native modes.
- > Supports local switching, direct device attachment and all mandatory and extended FC services (including zoning).
- > Engineered for Long Distance – transferring FC and Layer 2 Ethernet over IP for distances of thousands of kilometers without performance degradation, and with data and order delivery guaranteed.
- > Includes traffic shaping mechanisms such as Manual Rate Limitation and Congestion Avoidance to allow maintaining maximal possible performance in shared or low bandwidth IPWAN environments.
- > Uses Hardware Compression for more efficient utilization of low bandwidth or provisioned bandwidth connections - transferring more data while keeping the low price of the extension circuit.

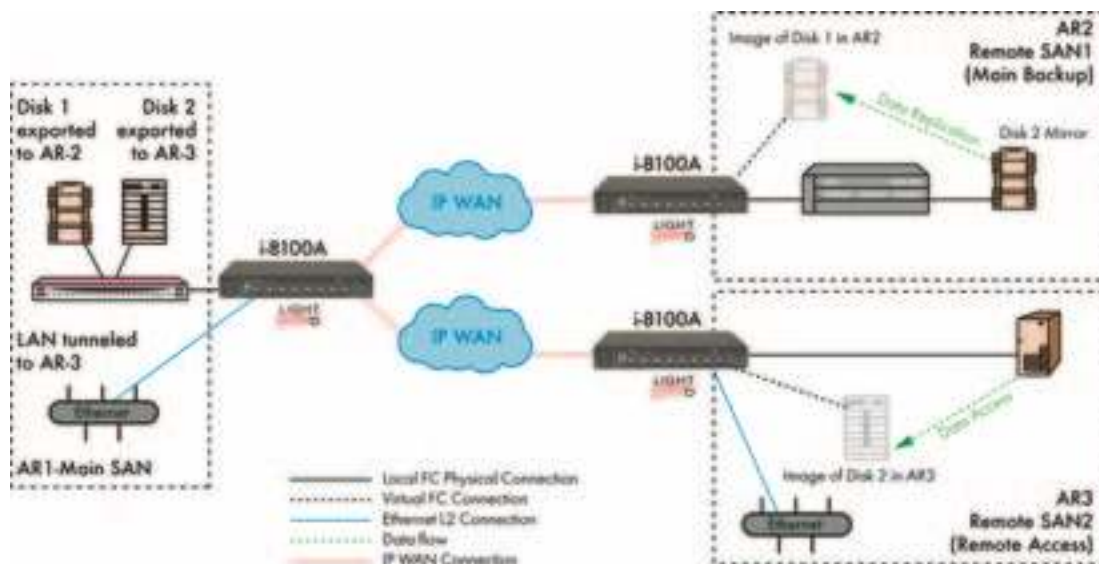



## ▶ i-8100B

The i-8100B is a flexible and powerful FC and Layer 2 GbE over routed IP gateway.



- > i-8100B has eight ports: Layer 2 Ethernet/GbE, FC and IP/GbE predefined per customer request and deployment objectives.
- > Implements trunking mechanism allowing cost effective deployments of up to seven parallel LAN or/and FC fabrics over a single IP WAN connection.
- > Presents a "B" port to the local FC switch. This provides an industry standard interface that lets all standard and proprietary FC services pass from one remote site to another.
- > Supports redundant connections for high availability and load balancing.
- > Engineered for Long Distance – transferring Layer 2 Ethernet and FC over IP for distances of thousands of kilometers without performance degradation, and with data and order delivery guaranteed.
- > Includes traffic shaping mechanisms such as Manual Rate Limitation and Congestion Avoidance to allow maintaining maximal possible performance in shared or low bandwidth IP WAN environments.
- > Uses Hardware Compression for more efficient utilization of low bandwidth or provisioned bandwidth connections - transferring more data while keeping the low price of the extension circuit.

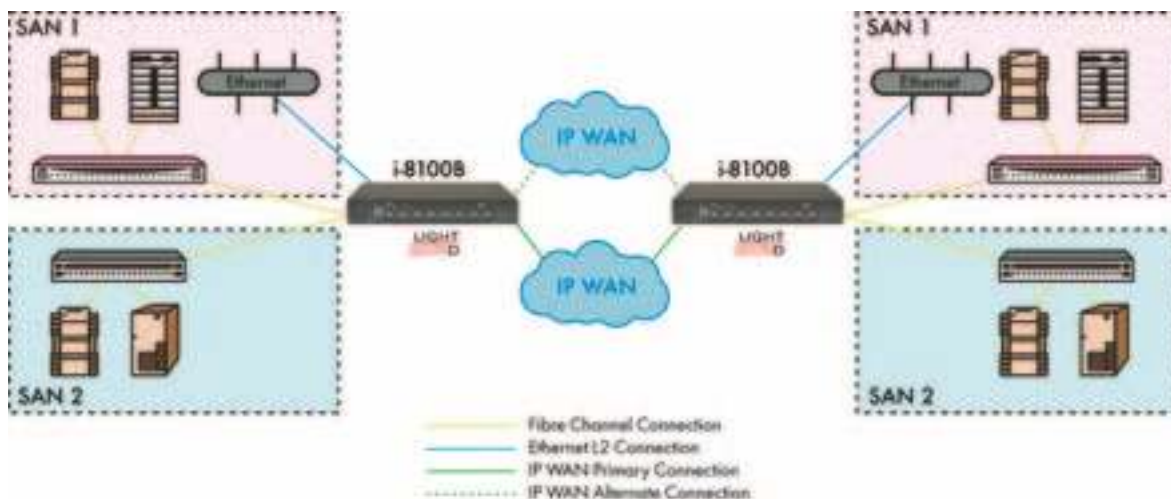

## ► i-8100E

The i-8100E is a multi-functional interconnection gateway of FC fabrics and LANs over routed IP Networks.



- > i-8100E has eight ports: Layer 2 Ethernet/GbE, FC, IP/GbE predefined per customer request and deployment objectives.
- > Implements E-Port connectivity and supporting all mandatory and extended FC services (PSS, FSPF, RSCN; Zone, Name, Configuration servers).
- > Supports interoperability in all standard modes of major FC switch vendors (Brocade®, McDATA®, Cisco®, etc.)\*, as well as proprietary/native modes.
- > Supports local switching and direct device attachment (F-Port).
- > Layer 2 device (GBE) may be attached and tunneled over FC fabric
- > Engineered for Long Distance – transferring FC and Layer 2 Ethernet over IP for distances of thousands of kilometers without performance degradation, and with data and order delivery guaranteed.
- > Includes traffic shaping mechanisms such as Manual Rate Limitation and Congestion Avoidance to allow maintaining maximal possible performance in shared or low bandwidth IPWAN environments.
- > Uses Hardware Compression for more efficient utilization of low bandwidth or provisioned bandwidth connections - transferring more data while keeping the low price of the extension circuit.

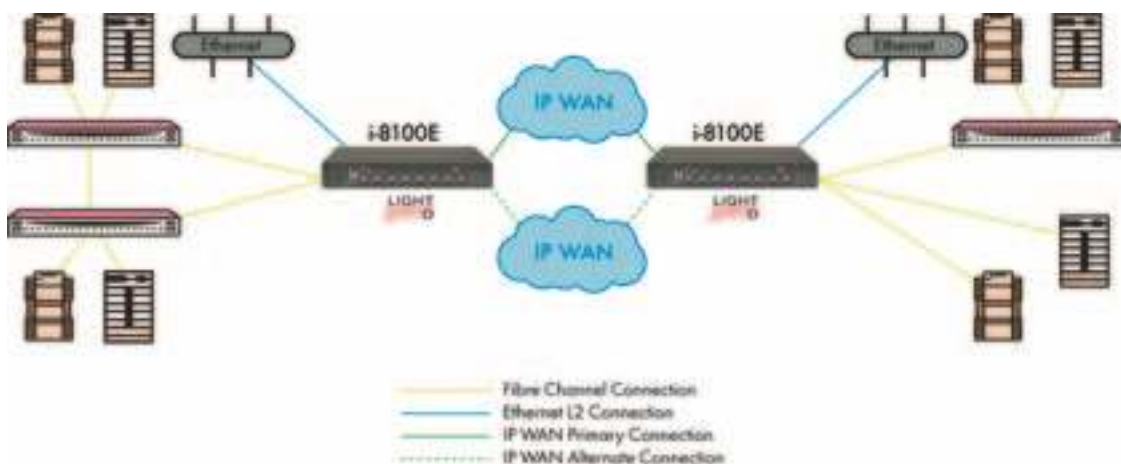

## ▶ i-7100F

The i-7100F is a flexible and powerful FICON and Layer 2 GbE over routed IP gateway.



- > i-7100F has eight ports: Layer 2 Ethernet/GbE, FICON and IP/GbE predefined per customer request and deployment objectives.
- > Can extend FICON devices without FICON director or switches
- > Implements trunking mechanism allowing cost effective deployments of up to seven parallel FICON channels and/or LANs over a single IPWAN connection.
- > Supports redundant connection for high availability and load balancing.
- > Engineered for Long Distance – transferring FICON and Layer 2 Ethernet over IP for distances of thousands of kilometers without performance degradation, and with data and order delivery guaranteed.
- > Includes traffic shaping mechanisms such as Manual Rate Limitation and Congestion Avoidance to allow maintaining maximal possible performance in shared or low bandwidth IPWAN environments.
- > Uses Hardware Compression for more efficient utilization of low bandwidth or provisioned bandwidth connections - transferring more data while keeping the low price of the extension circuit.

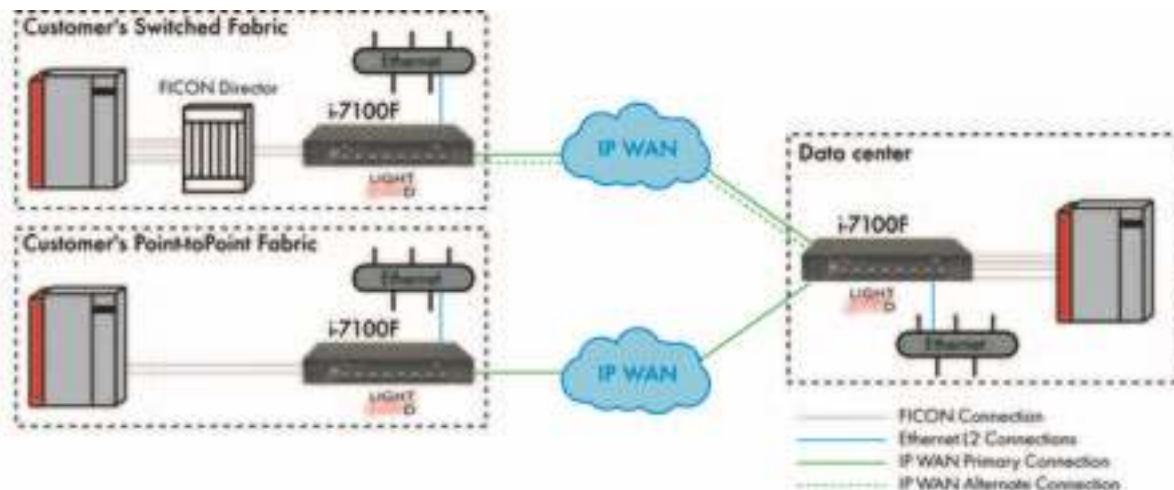

# ▶ i-1100 INTELLIGENT FCV (FICON BRIDGE) OVER ROUTED IP GATEWAY

- > i-1100 has two ports: FCV (FICON Bridge) and IP/GbE predefined
- > Offers a truly flexible and affordable solution, to extend legacy devices working with ESCON interfaces using the FCV protocol
- > Offers transparent and simple to implement gateway in a compact 1U design
- > Uses existing FICON/FC cabling infrastructure
- > Engineered for Long Distance – transferring FCV over IP for distances of thousands of kilometers without performance degradation, and with data and order delivery guaranteed
- > Includes traffic shaping mechanisms such as Manual Rate Limitation and Congestion Avoidance to allow maintaining maximal possible performance in shared or low bandwidth IP WAN environments
- > Uses Hardware Compression for more efficient utilization of low bandwidth or provisioned bandwidth connections.





## ▶ i-8100A-SMB INTER FABRIC ROUTING GATEWAY

The i-8100A-SMB offers cost effective solution for small and medium businesses for interconnecting remote SANs and LAN over routed IP Networks.



- > i-8100A-SMB has four ports: 2 FC ports, one Layer 2 Ethernet/GbE and one IP/GbE port.
- > Embedded AR/DAT engine interconnect remote SANs without actually merge them - creating non-disruptive SANs which can share devices in a secure way.
- > Supports interoperability in all standard modes of major FC switch vendors (Brocade, McDATA, Cisco, etc.), as well as proprietary/native modes.
- > Supports local switching, direct device attachment and all mandatory and extended FC services (including zoning).
- > Engineered for Long Distance – transferring FC and Layer 2 Ethernet over IP for distances of thousands of kilometers without performance degradation, and with data and order delivery guaranteed.
- > Includes traffic shaping mechanisms such as Manual Rate Limitation and Congestion Avoidance to allow maintaining maximal possible performance in shared or low bandwidth IPWAN environments.
- > Uses Hardware Compression for more efficient utilization of low bandwidth or provisioned bandwidth connections - transferring more data while keeping the low price of the extension circuit.

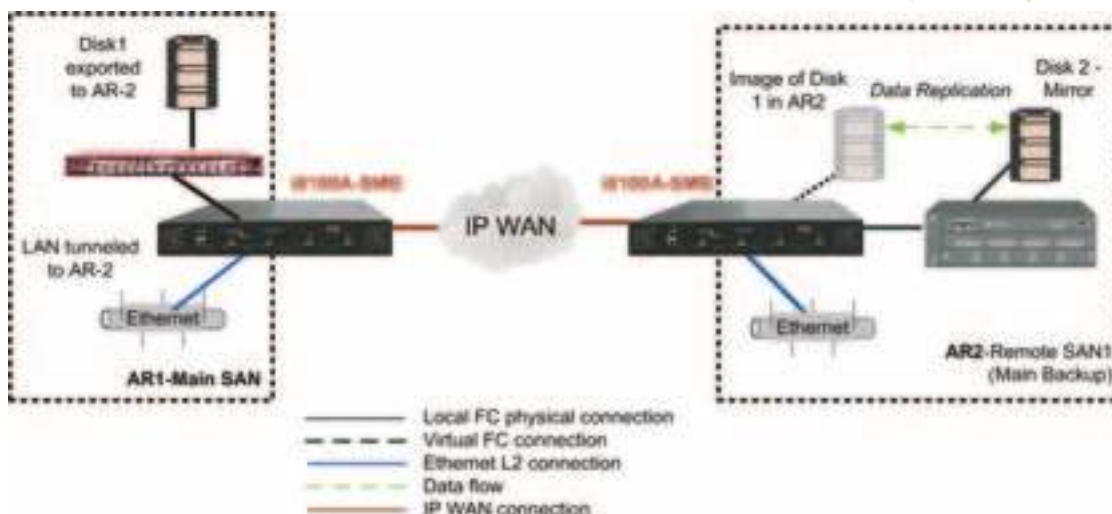



# ▶ i-8100B-SMB COST EFFECTIVE FC EXTENSION GATEWAY

The i-8100B-SMB gateway offers a cost effective solution for small and medium businesses for extending FC and Layer 2 GbE over routed IP Networks.



- > i-8100B-SMB has four ports: 2 FC ports, one Layer 2 Ethernet/GbE and one IP/GbE port.
- > Implements trunking mechanism allowing cost effective deployments of up to three parallel FC fabrics and LAN over a single IPWAN connection.
- > Presents a "B" port to the local FC switch. This provides an industry standard interface that lets all standard and proprietary FC services pass from one remote site to another.
- > Engineered for Long Distance – transferring Layer 2 Ethernet and FC over IP for distances of thousands of kilometers without performance degradation, and with data and order delivery guaranteed.
- > Includes traffic shaping mechanisms such as Manual Rate Limitation and Congestion Avoidance to allow maintaining maximal possible performance in shared or low bandwidth IPWAN environments.
- > Uses Hardware Compression for more efficient utilization of low bandwidth or provisioned bandwidth connections - transferring more data while keeping the low price of the extension circuit.

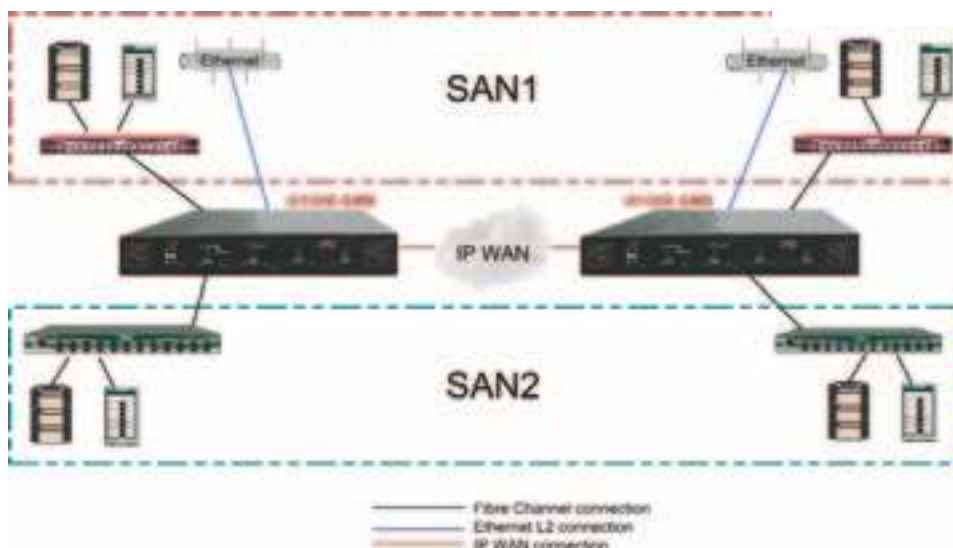

## ▶ i-8100E-SMB COST EFFECTIVE FC SWITCHING GATEWAY

The i-8100E-SMB multi-functional interconnection gateway offers cost effective solution for small and medium businesses for extending FC fabrics and LAN over routed IP Networks.



- > i-8100E-SMB has four ports: 2 FC ports, one Layer 2 Ethernet/GbE and one IP/GbE port.
- > Implements E-Port connectivity and supporting all mandatory and extended FC services (PSS, FSPF, RSCN; Zone, Name, Configuration servers).
- > Supports interoperability in all standard modes of major FC switch vendors (Brocade, McDATA, Cisco, etc.), as well as proprietary/native modes.
- > Supports local switching and direct device attachment (F-Port).
- > Layer 2 device (GBE) may be attached and tunneled over FC fabric.
- > Engineered for Long Distance – transferring FC and Layer 2 Ethernet over IP for distances of thousands of kilometers without performance degradation, and with data and order delivery guaranteed.
- > Includes traffic shaping mechanisms such as Manual Rate Limitation and Congestion Avoidance to allow maintaining maximal possible performance in shared or low bandwidth IPWAN environments.
- > Uses Hardware Compression for more efficient utilization of low bandwidth or provisioned bandwidth connections - transferring more data while keeping the low price of the extension circuit.

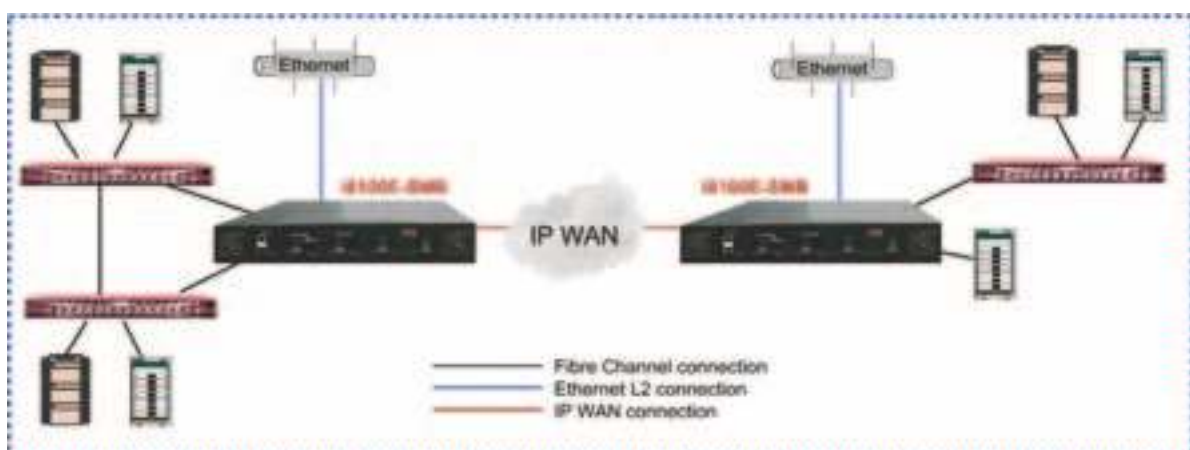

HEADQUARTERS:  
101 East Park Boulevard  
Suite #600  
Plano TX 75074 - USA  
Phone: +1 972 516 3740  
Fax: +1 972 516 3741

EMEA OFFICES:  
66, rue Pierre Charron  
75008 Paris - France  
Phone: +331 45 62 84 84  
Fax: +331 45 62 84 26  
email : [info@lightsand.com](mailto:info@lightsand.com)

Southern Europe Offices:  
Av. Boavista  
1277/81 - 3º - Sala 1  
4100-130 Porto - Portugal  
Phone: +351 220 107 501  
Fax: +351 220 107 518

[WWW.LIGHTSAND.COM](http://WWW.LIGHTSAND.COM)